

UTILIZING WASTE HYDROGEN FOR ENERGY RECOVERY USING FUEL CELLS AND ASSOCIATED TECHNOLOGIES

Copyright Material IEEE
Paper No. PCIC-2004-14

Paul Buddingh, P.Eng.
Member, IEEE
Universal Dynamics
100-13700 International Place
Richmond, BC V6V 2X8
Canada

Vince Scaini, P.Eng.
Member, IEEE
SatCon Power Systems
835 Harrington Crt.
Burlington, ON L7N 3P3
Canada

Leo Casey, PhD
Member, IEEE
SatCon Technology
161 First Street
Cambridge, MA 02142-1228
USA

Abstract- Electrochemical and other process industries frequently vent or flare hydrogen byproducts to the atmosphere. This paper will discuss hydrogen power conversion methods including fuel cells and combustion technologies. This paper presents an overview of some of the practical implementation methods available, and the challenges that must be met. The pros and cons of distributing power to either the AC power system or DC process bus are examined. This technology is expected to become cost-competitive as energy prices continue to climb and fuel cell proficiency matures.

Index Terms – Hydrogen, Fuel Cells, DC/DC Converters, Inverters

I. INTRODUCTION

The amount of waste hydrogen produced varies widely depending on the process in a particular plant. This paper examines alternatives for plants that produce more than 4 metric tones of hydrogen per day. Power generation greater than 1 megawatt is the focus of this paper.

TABLE 1
GENERATION SYSTEM ATTRIBUTES [1]

Type	Size	Efficiency (%)
Reciprocating Engines	50 kW-6 MW	33-37
Micro Turbines	10 kW-300 kW	20-30
Fuel Cell, PAFC	50 kW-1 MW	40
Fuel Cell, MCFC	250 kW-3 MW	47-50
Fuel Cell, SOFC	5 kW-3 MW	45-65
Fuel Cell, PEMFC	<1 kW-1 MW	34-36

II. HYDROGEN BASICS

Hydrogen is often discussed favorably as an environmental friendly fuel. The combustion of hydrogen produces no carbon dioxide (CO₂), particulate, or sulfur emissions. What is not so obvious is that as technology has advanced over the last several hundred years we have increased our use of hydrogen fuel. As the conventional fuel of choice, progressed from wood to coal then to oil and natural gas, the percentage of carbon in our fuel has declined and the percentage of hydrogen increased. Taking this progression to the extreme,

one could argue that we will eventually be using 100% hydrogen fuel without the motivation of environmental benefits.

Hydrogen has higher energy per unit of mass, but lower energy per unit volume than any other fuel. By weight, hydrogen “carries” three times the energy of our most common fuels. For example, 1 kg of hydrogen has approximately the same amount of energy as 1 US gallon of gasoline (approximately 3 kg). The major downside of hydrogen is its poor volumetric energy density, making storage and transportation a fundamental challenge. To help resolve this problem, the hydrogen industry is currently certifying 10,000 psi hydrogen cylinders. Even at these extreme pressures, a hydrogen cylinder of 1 ft inside diameter 4 ft long (about 23 US gallons by volume at 10000 psi, or 15,000 US gallons at atmospheric pressure) would contain the equivalent energy of a conventional 5 US gallon gasoline container at atmospheric pressure. In addition to the certification of high-pressure storage cylinders, one must also consider the challenge of the compressors required to boost the gas to 10,000 psi. Currently, there are several commercially available hydrogen compressors available that achieve these pressures.

Hydrogen is actually safer than media reports of the past suggest. The infamous burning and subsequent explosion of the Heindenberg airship is used as an example when the dangers of hydrogen are discussed. However, it was actually the flammable coating of the Dirigible’s balloon that caused most of the damage. The small size of the hydrogen molecule results in free hydrogen (a leak) dispersing very quickly in the atmosphere, and its chances of creating an explosion are somewhat less than conventional fossil fuel vapors.

The great advantage of many electrochemical plants is the continuous production of hydrogen that may be utilized continuously to produce power.

III. HYDROGEN POWER TECHNOLOGIES

A. Fuel Cells

Fuel cells convert chemical energy into electrical energy. This principle has been known for close to two centuries and the first kilowatt-sized fuel cells were developed over forty years ago. It is the direct conversion of fuel to electricity that enables fuel cells to have high efficiencies when compared to the heat engines in common use today.

The basic schematic of a typical fuel cell is shown in Fig. 1. "Every fuel cell consists of a fuel electrode (anode) and an oxidant electrode (cathode), separated by an ion conducting electrolyte. Incoming gaseous fuel is ionized to produce hydrogen ions and electrons at the anode. The electrolyte will conduct only ions; electrons flow away from the anode through an external circuit. Oxygen atoms at the cathode react with migrating hydrogen ions from the electrolyte and combine with electrons from the external circuit to produce water".[2] The water produced can be in the form of liquid or gas depending on the fuel cell operating temperature.

The electrolyte current flows via H⁺ ions in acid electrolytes, carbonate ions flow in molten carbonate electrolytes and oxide ions flow in solid oxide electrolytes for the different fuel cell types. The chemical reaction for an acid electrolyte system such as a Proton Exchange Membrane Fuel Cell (PEMFC) is as follows:

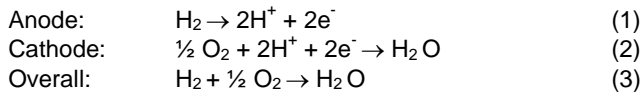

where:

H₂ hydrogen gas
H⁺ positive hydrogen ion
e⁻ negatively charged ion
O₂ oxygen gas
H₂O water

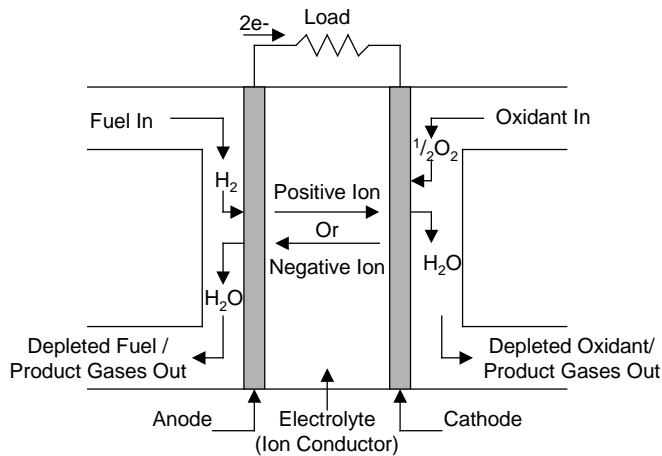

Fig. 1 Hydrogen-Oxygen Fuel Cell Basic Schematic [1]

Although the schematic in Fig. 1 may seem simple enough, other components such as the fuel processors and electrical power converters are required for a full fuel cell system. Power conditioning options for use in electro-chemical plants are outlined in section IV Power Distribution Methods.

The types of fuel cells are generally named for their electrolyte used. Table 1 lists the fuel cell types predominately available today along with operating temperatures and charge carriers.

The following sub-sections give a brief description of the fuel cells listed in Table 1. Detailed information on the construction and operation of these various fuel cells can be obtained from the references given.

TABLE 2
COMPARISON OF FUEL CELL TYPES [1][2]

Fuel Cell Type	Operating Temp. (°C)	Charge Carrier	External Reformer
Proton Exchange Membrane Fuel Cell (PEMFC)	80-100	H ⁺	Yes
Phosphoric Acid Fuel Cell (PAFC)	180-205	H ⁺	Yes
Molten Carbonate Fuel Cell (MCFC)	600-700	CO ₃ ²⁻	No
Solid Oxide Fuel Cell (SOFC)	600-1000	O ²⁻	No

1) *Proton Exchange Membrane Fuel Cell (PEMFC)*. The PEMFC uses an ion exchange membrane as an electrolyte, typically constructed of fluorinated sulfonic acid polymer or a similar polymer.

Water management in the membrane is important for its performance in that the water byproduct should not evaporate faster than it is produced due to the membrane hydration requirement. Thermal ratings of the polymer along with problems of water balance limit the temperature of the PEMFC. This low temperature limitation dictates that a rich H₂ gas with minimal carbon monoxide (CO) (10 ppm desirable) or no CO be used as a fuel. CO contaminates the membrane, as do many other impurities, thereby reducing its efficiency or destroying it. Hence, when hydrocarbon fuels such as natural gas are used, a "reformer" fuel processor is required to produce H₂ gas free of contaminants.

Available H₂ gas from a chlor-alkali cell line can only be used as a fuel if the gas is processed to remove all contaminants such as chlorine gas (Cl₂). To date the level of acceptable Cl₂ contamination with any fuel cell is not known to any certainty. (Low temperature fuel cells such as PEMFCs are more susceptible to chlorine poisoning, Stable performances of PEMFCs have been demonstrated up to 10,000 h.) Their high power density, low operating temperature, and fast step response to load change make the PEMFC the system of choice for vehicle applications.

2) *Phosphoric Acid Fuel Cell (PAFC)*. The electrolyte used for PAFCs is 100% phosphoric acid concentrate. Due to low temperature operation, CO poisoning of the electro-catalyst is an issue if not addressed. Therefore, the use of a fuel processor (reformer) is also required. The use of concentrated acid and temperatures above 100°C make water management less of an issue when compared to PEMFCs. The PAFC is in commercial production. To date over 75 MW worth of PACFs are installed worldwide in stationary generation applications. Typical plants are in the range of 50 kW to 200 kW capacity, with the largest installed plant to date being 11 MW.

3) *Molten Carbonate Fuel Cell (MCFC)*. The electrolyte used is a mixture of alkali carbonates retained in a ceramic matrix. The alkali carbonates become a highly conductive molten salt with the high temperatures present in the MCFC. It is the carbonate ions in the salt that provide the ionic conduction. Similar to the hydrogen ions of (1), the MCFC has the following electrochemical reactions:

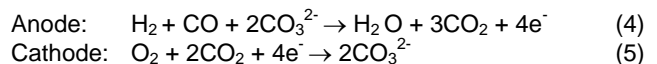

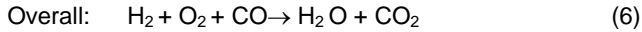

where:

H_2 hydrogen gas
 CO_3^- carbonate ion
 e^- negatively charged ion
 CO_2 carbon-dioxide gas
 H_2O water

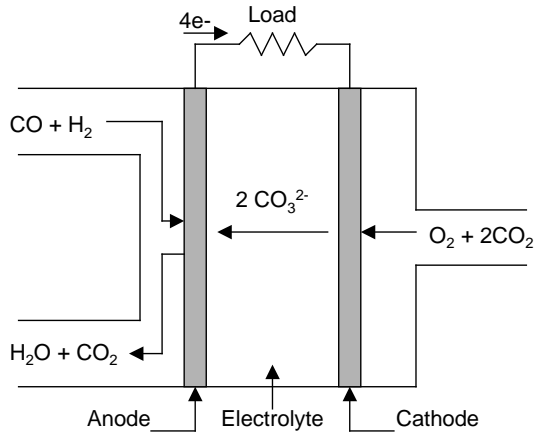

Fig. 2 Molten Carbonate Fuel Cell Schematic [2]

Little or no external fuel reforming is required since the higher temperatures rapidly oxidize the fuel internal to the fuel cell, with effective heat transfer for the reforming process. These higher operating temperatures also provide the opportunity to boost overall system efficiency by utilizing heat recovery systems. Another advantage of the MCFC is that it can consume fuels containing CO or CO₂. However, H₂ gas cannot be used directly as a fuel since CO₂ is used on the cathode side of the cell. Therefore, in our application CO₂ would need to be supplied from an alternative source (see Fig. 2). The higher temperatures put harsh demands on the corrosion stability of components. However, even in this severely corrosive environment, the fuel cell stack typically has a five-year life making it a more suitable fuel cell for stationary applications.

4) *Solid Oxide Fuel Cell (SOFC)*. The solid electrolyte in the SOFC is a metal oxide. The cells produced today may be planar or tubular. The tubular cells operate at 1000°C and the planar cells operate between 600 and 800°C. Like the MCFC, the SOFC does not require an external reformer. The use of heat recovery systems again makes it ideal for stationary applications, however both high temperature fuel cells have a slower load following capability, making it difficult to meet load step responses. These system response issues can be dealt with by employing load-leveling components such as an energy storage device or a resistive element.

As an option, SOFC and MCFC system integrators are offering fuel cells combined with a gas turbine. The turbine is powered from the waste heat of the fuel cell, thereby operating these systems at higher efficiencies.

The SOFC operates via the transport of oxide ions:

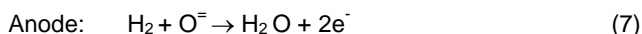

where:

H_2 hydrogen gas
 e^- a negatively charged ion
 O_2 oxygen gas
 H_2O water

Carbon monoxide (CO) as well as hydrocarbons (CH₄) can be used as fuels to produce an H₂ stream that is internally reformed. The ability to utilize an H₂ stream also makes it an ideal candidate for chlor-alkali applications.

5) *Alkaline Fuel Cell (AFC)*. The electrolyte in an AFC is 85% by weight concentrate of potassium hydroxide (KOH) for cells operating at 250°C and 35% to 50% by weight concentrate of KOH for cells operating at 120°C. The AFC was developed for the Apollo Space Program using pure H₂ as a fuel stream. Small amounts of CO₂ in the fuel would react with the KOH to form a solid carbonate, thereby destroying the electrolyte's ion mobility. This would be detrimental to the cell making the AFC limited in practical terrestrial applications.

B. Maximum Power Point Tracking – Power Point Control

A typical fuel cell polarization curve is shown in Fig. 3. The specifics are somewhat different for various fuel cells but the general polarization relationship is as shown. It is interesting to note that:

- As the load current increases from zero to the maximum, the fuel cell voltage drops by 50% to 70%. This large voltage and current variation affects the rating of the DC/DC converter components due to higher current required at lower voltages, and therefore cost and efficiency.
- The fuel cell power curve has a pronounced maximum. Beyond the maximum point, any increase in the load current leads to reduced power. Operation at currents higher than the maximum power point current also leads to degradation of the fuel cell.

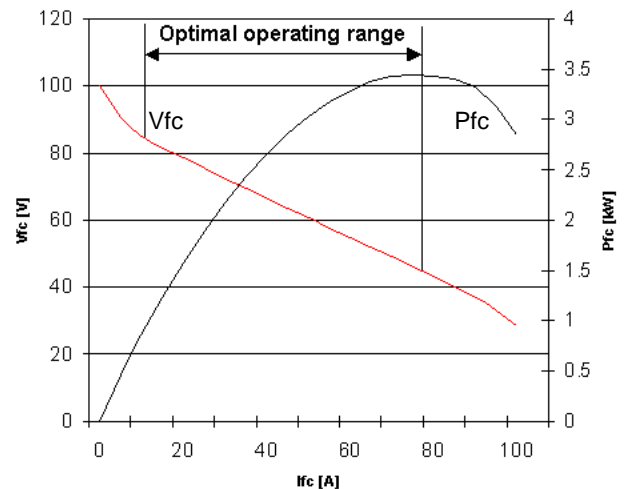

Fig. 3 Typical PEM Fuel Cell Polarization Curve

where:

V_{fc} Fuel cell stack voltage
I_{fc} Fuel cell stack current
P_{fc} Fuel cell stack power

Operating the fuel cell at or near its peak power point is clearly advantageous from a system perspective. When we consider the overall system, we must keep in mind that at reasonable power levels, for a given power transfer, the power converter efficiency is higher at higher voltages (higher impedance).

2) *Avoiding Abrupt Load Transients to Enhance Fuel Cell Longevity.* A typical system design challenge is that fuel cells operate optimally under steady power conditions. If the output of the fuel cell exactly matches the needs of the load (matching power, voltage, and current), OR the load can take whatever the fuel cell provides, then the fuel cell can be directly connected to the load. Such is the case for the application of this paper and would only be violated if the entire electrical load were suddenly disconnected or shed. This is in stark contrast to stand alone power systems where the power source experiences wide load variations and rapid load transients. With load variations, fuel cells operate less efficiently as the hydrogen and oxygen flow rates do not match the output power being drawn. More importantly, the fuel cell reliability is reduced. Both laboratory and field testing have shown that the reliability and the life expectancy of fuel cells tested with constant resistive loads is far superior to fuel cells connected to varying real world loads.

If the hydrogen production exceeds that required for reliable operation with the electrical demand power (or if the load abruptly goes off line), there are the following options:

- The hydrogen could be flared or boiler combusted for heating applications;
- Storage of either the excess hydrogen or the excess electrical energy.

The straight combustion options are well understood and involve the instantaneous use of the chemical energy. Both storage options give additional flexibility and potentially enhanced system operation. Nationally there are incentive schemes to reduce power consumption when the grid is under the most stress (either loss of generating assets or excessive demand). So a system that stores either hydrogen or excess generated electricity would be advantageous.

IV. SUBSTITUTING HYDROGEN FOR CONVENTIONAL FOSSIL FUELS

Hydrogen does occupy more space than any other fuel, whether it is in gaseous or liquid state. However, new tanks are providing improved storage of compressed hydrogen gas. The U.S. government recently certified 5,000 psi hydrogen tanks for use in automobiles. The German government has certified 10,000 psi tanks; and the U.S. is likely soon to follow. 12,500 psi tank are being developed that should be certified within the next two years. A European automobile company has used liquid hydrogen, which provides more hydrogen per volume than gaseous hydrogen, but is more expensive to produce and convert. Liquid hydrogen tanks also require venting of the gas as it warms in the tank. The same automobile company claims that their tanks will not require any venting for up to one week.

A. Boilers

At present, boilers are the most popular use of surplus hydrogen gas in electrochemical plants. The hydrogen is first scrubbed of objectionable process residuals, collected and pressurized. It is fed into a boiler's burner equipped with a hydrogen fuel delivery nozzle. These burners typically burn a mixture of natural gas or other conventional fuels and the waste hydrogen. The steam produced is used elsewhere in the process. This has proven to be a worthwhile investment in any plant that can use the steam.

B. Stationary Internal Combustion Engines

The storage and transportation issues normally associated with hydrogen power are not a concern in stationary electrochemical plant applications. An electrochemical plant typically operates continuously providing a constant supply of hydrogen. A hydrogen powered internal combustion engine, powering a generator, could therefore supply a constant supply of electrical power.

Literature suggests that a hydrogen intake system will be very similar to that used currently for Natural Gas fueled engines. Electrical generator sets that use natural gas fuel are commonly available from many vendors. There are both pure natural gas and blended-fuel - fuel units that burn a mixture of diesel fuel and natural gas. These types of generators have a substantial life cycle cost due to on-going maintenance of the engine. One manufacturer recommends a complete engine rebuild after 10-30,000 hours of operation. The lower figure is for natural gas only engines, the higher for the diesel/natural gas type.

At present, there are no commercially viable large (1 MW+) systems available to convert gas turbines and other types of generation systems to hydrogen (or natural gas) use. There are several patents on hydrogen fuel conversion systems. Codes and Standards for use of hydrogen in these applications are still being developed.

C. Gas Turbines/Generators

Micro turbines in the 30 kW to 100 kW size are gathering large interest in the media. Again, natural gas is a popular fuel, but hydrogen applications are unknown. Furthermore, the cost is presently prohibitive to parallel these smaller units to obtain the higher power levels (> 1 MW) for the application addressed in this paper. Larger turbines, above 300 kW in size, have higher air emissions and may require pollution controls. Higher noise levels and air-quality permitting are other issues facing users considering implementation of larger turbines.

D Cogeneration

The next step beyond simply burning the hydrogen to produce steam would be a system that generates steam for process use and also powers a steam turbine-generator.

The authors have investigated using hydrogen in a cogeneration scheme. For example, one process reviewed produced 4 tons/day of H₂. A small boiler would burn the hydrogen and produce steam. Due to efficiencies of this

technology, only very small steam turbines, at most 600 kW, could be generated using a boiler with condenser. If a condenser is not used, and the steam is simply discharged to the atmosphere, the so-called "bottoming turbine" could generate only 3 kW to 400 kW. The cost of hardware for these very small turbines is very high for the amount of power generated. Presently payback is too long to make this type of scheme attractive to management even with green power utility incentives.

Preliminary calculations suggest that the economics start to become promising for large plants producing more than 12 tons of hydrogen per day.

V. FUEL CELL/GAS TURBINE HYBRID SYSTEMS

Hybrid power systems consisting of high temperature fuels cells and gas turbines have been in service for several years. Several companies have ongoing field trial and demonstration units operating. The size of these units runs from about 250 kW to 5 MW [3].

Typically, these power plants use either the solid oxide (SOFC) or molten carbonate (MCFC) fuel cell in combination with a gas turbine to increase overall thermal efficiency, with predicted efficiencies of 65% to 75%. This compares to 60% for the best of the conventional thermal combined cycle generation plants in common use today. Currently, efficiency of the hybrid systems is in the 60% range.

High temperature fuel cells are used in this application, as they operate well under the pressures and temperatures needed. In the case of SOFC, the pressurized environment improves the fuel cell efficiency. The turbine is able to recycle thermal and pressure energy that would normally be discarded.

Fuel and water are sent from a heat recovery unit (HRU) that produces steam, which is mixed with fuel heated by the HRU and then supplied to the fuel cell and then to the turbine. Hybrid fuel cell systems supply electricity from both the fuel cell and turbine generator.

VI. POWER DISTRIBUTION METHODS

A. Connecting Hydrogen Power Source to the Local Utility system

Any power generation system with an AC connection will be complicated by the requirements of the Utility. Anyone who connects generating capacity to the grid must coordinate the connections with the local utility. There is presently no North American-wide standard for interfacing to the grid, although there are committees working on the issue. Until the interconnection is standardized each installation will require custom metering and protection systems.

The first step in the process involves preplanning and gaining regulatory approval. At present, this can be very time consuming and costly. This often lengthy, procedure can require many meetings, reports, and paperwork with various utility and regulatory agencies to receive the necessary approvals. In addition to the local utility and electrical inspection authority, there may be technical and safety authorities that may or may not be familiar with these supplemental energy supply systems. In many cases, the

emissions must meet the approval of the local environmental authorities, which can be a major hurdle in itself.

B. "Green Power" Utility Incentives

Factors which help make these methods cost effective, are the various "Green Power" incentives offered by many North American power companies. Incentives of 30% to 50% of the total project cost are customary for well-documented projects with rigorous feasibility studies. There are many different programs available with different requirements and funding levels. The following criteria are representative of what is available.

The projects are typically approved through a competitive review process. To qualify, projects usually need a simple payback of less than 2 years. The project must be fully operational within 18 months. A minimum of 300 MWh/yr in electrical energy savings is required and it must be a new project.

Incentives are usually paid in installments. For instance, 25% may be paid at the time all of equipment for the project has been ordered, 50% paid at the time the project is commissioned service and installed, and the remaining 25% at the time the project has been in service for twelve months and the energy savings have been verified.

C. Generators to Grid

Many energy suppliers are currently developing interconnection standards for small power producers. One good source of information is www.micropower-connect.org [10] a government/industry collaboration.

At this time, however, most suppliers are still using standards intended for large power interconnections. These standards require a substantial investment of time and money to connect to the power grid, which makes this type of interconnection less attractive.

D. Fuel Cell to AC Grid

A number of circuit configurations are available for Power Conversion Systems (PCS). Depending on the fuel cell voltage, output line voltage requirement, fuel cell source isolation to ground, and the VA rating of the PCS one or more circuit configurations can be selected from economic and efficiency considerations.

1) *Single Stage PCS*. This the most basic of PCSs usually consisting of an inverter with six switching devices, an AC line filter, and an isolation/voltage matching transformer. Important criteria for grid connected PCSs is that they meet *UL1741 Standard for Inverters, Converters and Controllers for Use in Independent Power Systems*, and its interconnection meets *IEEE P1547 Standard for Interconnecting Distributed Resources with Electric Power Systems*.

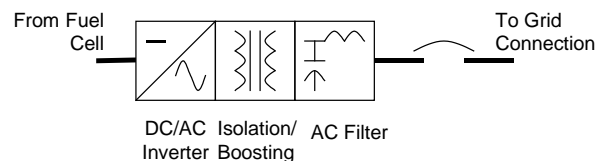

Fig. 4 Single stage grid connected PCS

2) *Two Stage PCS with Chopper Input.* The term two-stage PCS comes from the use of a boost chopper input to the inverter. This configuration is useful for low-voltage fuel cells since the boost chopper boosts the voltage input to the inverter, thereby reducing the inverter current and its losses. By reducing the inverter current, the overall PCS size and cost can be substantially reduced depending on the DC source voltage. Another possible advantage of the boost converter is that the intermediate DC bus can be boosted high enough so that the inverter output matches the grid connection voltage. If the DC source is floating (not grounded), the PCS inverter need not be isolated and the isolation/voltage matching transformer can be eliminated.

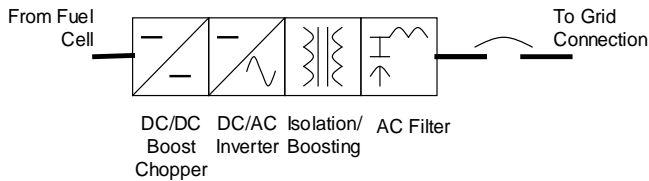

Fig. 5 Two-stage PCS with boost chopper input

3) *PCS with Switch-mode Input.* Similar to the configuration of the two-stage PCS with boost chopper, the PCS with switch-mode input boosts the DC input to the inverter. The switch-mode transformer provides isolation and voltage boosting, eliminating the physically larger output transformer. This circuit configuration is most common in PCSs smaller than 10kVA. The reduced size of the high frequency isolation transformer gives a cost advantage to this configuration, especially for very low-voltage DC inputs to the PCS. However, the PCS is not as efficient as the input DC voltage increases. One other issue to consider with this configuration is that utilities often require an isolation transformer between the inverter and the point of common coupling to ensure that no DC offset current is injected into the utility from the inverter.

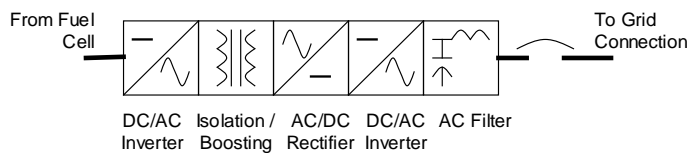

Fig. 6 PCS with switch booster mode input

C. Connecting Hydrogen Power Source to the DC Process Bus

A DC connection directly to the plant process bus greatly simplifies the connection procedure. A major cost saving is the time required to meet all the requirements set out by various authorities in order to connect to the grid. This would normally require several studies costing tens of thousands of dollars. Meeting complex permitting requirements frequently uses up valuable resources. The metering and protection hardware costs are also substantial.

It is procedurally much easier to connect to the process bus within the plant. Energy saving will still occur and the utilities

energy saving incentives can still be pursued since power consumption will be reduced.

Moreover, often the “Green Power” incentives by the utilities still apply and the approval process can be streamlined since the contact at the utility is often the same representative that is normally the plant’s utility representative who is generally very aware of the plant’s electrical needs. The capital required to complete the project can be partially paid by the utilities energy saving incentive programs.

1) *Fuel Cell to DC Process Bus.* If the fuel cell is in close proximity to the process bus, the power can be fed directly to the rectifier output before the current transducer (Fig. 7) or to the intermediate chopper rectifier bus (Fig. 8) via a chopper or switch-mode PCS. The advantages of this approach are both economic as well as higher efficiency. If the fuel cell can share a common voltage with the process bus, a non-isolating chopper PCS would be the most efficient and economic solution.

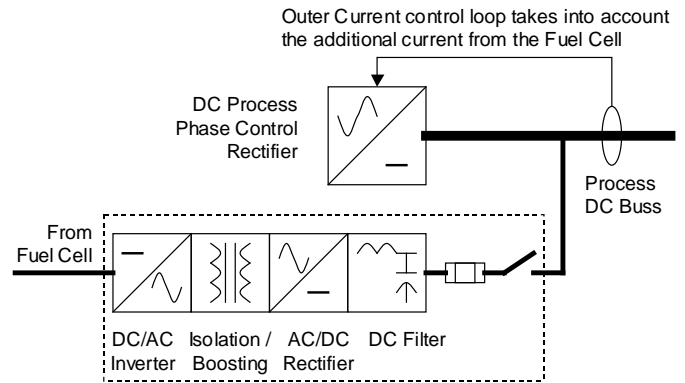

Fig. 7 Fuel Cell PCS connection to process bus

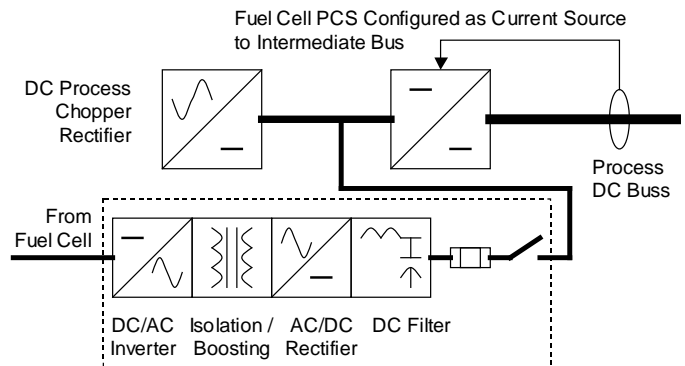

Fig. 8 Fuel Cell PCS connection to intermediate chopper bus

To address the one weakness in these outlined systems, which would be the rapid unloading of the process power bus, there are several approaches one could consider:

- The excess electricity could be stored briefly while the fuel cell feed stock was adjusted (typically in a battery, electrolyzer or super-cap system).
- Transfer energy back to the grid, which can be used to safely ramp down the fuel cell power production.

VII. PRESENT STATE OF THE ART FOR OPERATIONAL REAL WORLD STATIONARY FUEL CELLS

Since fuel cell hydrogen consumption response is limited, a certain amount of H₂ storage would need to be considered for system "Blips", particularly when chlor-alkali cell lines come on and off line. The size of storage required would greatly depend on the fuel cell's hydrogen consumption and operation requirement.

VIII. CONCLUSIONS

The challenges and hurdles to overcome in a practical system have been outlined in this paper. Today, the most significant obstacle is cost. At present, fuel cell systems cost between \$4,000 to \$5,000 USD per kilowatt (kW). Manufacturers of all fuel cell types are working to reduce costs with the goal to be in the \$1,500/kW range within 10 years. At this price level, fuel cells will be competitive with today's popular power sources.

This goal will be achieved with advances in mass production technology and widespread use. Some very motivated groups are driving the effort to overcoming the hurdles identified. The automotive industry has made huge investments and continues to propel this technology forward. Stationary fuel cell deliveries are ramping up with increased reliability and length of service. High temperature fuel cells for both cogeneration power plants and smaller units for home use are being produced in increasing numbers.

History has demonstrated that with the mass adoption of technology, technical issues are overcome and costs come down. This was true for electrification a century ago and more recently for computers. Fuel cells will soon be in widespread use and no doubt our children will wonder what all the excitement was about with these soon to be ubiquitous machines that produce power so effortlessly.

IX. REFERENCES

- [1] EG&G Services Parsons, Inc., *Fuel Cell Handbook*, Morgantown, WV, U.S. Dept. of Energy, Office of Fossil Energy, National Energy Technology Laboratory, October 2000.
- [2] I. Da Cunha, R. Stasko, C. Zaluski, *Fuel Cells and the Hydrogen Economy-Strategic Options for Ontario*, Toronto, ON: Kinectrics, Dec. 2002.
- [3] K. Wicker, *High-Temperature Fuel Cells for Stationary Power: A Long Hot Road to the Promised Product*, The Distributed Energy Service: DE-17, March 2002.
- [4] J. Holdahl and T. VanConant, *Demystifying Buck Inductors*, Power Conversion & Intelligent Motion, July 2001, pp 94.
- [5] J. Schaefer, *Rectifier Circuits Theory and Design*, New York, NY: John Wiley & Sons, 1965.
- [6] UL1741 Standard for Inverters, Converters and Controllers for Use in Independent Power Systems
- [7] IEEE P1547, *Standard for Interconnecting Distributed Resources with Electric Power Systems*.
- [8] P.S. Maniscalco, V. Scaini, & W.E. Veerkamp, "Specifying DC Chopper Systems for Electrochemical Applications", *Conf. Rec. IEEE/IAS PCIC*, 1999, pp 161-169.
- [9] T.K. Bose et al, "Hydrogen Energy Challenges and Opportunities" Hydrogen Research Institute Universite de Quebec a Trois.
- [10] <http://www.micropower-connect.org/>.
- [11] R. S. Gemmen, "Analysis for the Effect of Inverter Ripple Current on Fuel Cell Operating Conditions," Presented at the 2001 International Mechanical Engineering Congress and Exposition, New York, NY, 11-16 Nov. 2001.

X. VITA

Paul C. Buddingh graduated from Lakehead University in Thunder Bay, Ontario, Canada with a degree in Electrical Engineering. Upon graduation, he spent several years working out of Toronto, Canada as an electrical consulting engineer working in heavy industry. In 1991, he co-founded a company that developed a new magnetic approach to solving zero sequence harmonic problems in low voltage systems. In 1997, he moved to Vancouver, Canada and joined Universal Dynamics. He has been designing power systems for electrochemical facilities for more than 15 years. His work is centered on designing high reliability power systems for difficult loads, power converter issues and resolving power system problems for a number of industrial customers across the Americas. He is a registered Engineer in the provinces of Ontario, Manitoba and British Columbia and an author of several IEEE papers. He is currently the Vice-Chair of the electrochemical subcommittee of the IEEE PCIC and chairman of the IEEE C34.2 rectifier standard working group.

Vince Scaini graduated with a B.A.Sc. in Electrical Engineering from the University of Toronto, Canada in 1979. He spent three years as a research associate in the University of Toronto, and Inco Research in Birmingham, England working in the fields of electro-metallurgy and power electronics. Joining Inverpower Controls Ltd, in 1982, he has been involved in various engineering and management roles, including the start-up of original manufacturing facilities, and design of converters for numerous power applications. At SatCon, his current role as Manager of Application Engineering and Proposals, Mr. Scaini is a key member of the Sales and Marketing Team. He is a registered member of the Professional Engineers of Ontario (PEO); Past director of the Arthritis Society, Ontario Division; and author of numerous IEEE papers. Mr. Scaini is currently Secretary of the Electrochemical Subcommittee of the Petroleum and Chemical Industry Committee (PCIC) Industry Applications Society (IAS) and Chair of the IEEE Toronto section IAS.

Leo F. Casey graduated from the University of Auckland in New Zealand in 1980. He worked for the New Zealand Department of Scientific and Industrial Research before attending MIT on a Fulbright Scholarship from 1981-1988, obtaining his doctorate in 1988. His expertise is in analog circuit design, Power Electronics and Systems, Device Physics and Modeling and Control. He has worked for Philips Labs, ITS, SatCon, and taught on the faculty of the University of Auckland. He is currently the CTO and Chief Engineer of SatCon, and Associate Editor of the Power Conversion Transactions of the Power Engineering Society of the IEEE. He has received Fulbright, Commonwealth, NZ-PostGrad and MIT-Instructorship Scholarships. His academic awards include NZ Junior Scholar, NZ Senior Scholar, MIT Hennie Teaching Award, and an IEEE Power Electronics Plenary Session Award. His Lifesaving interests culminated in a Queens Lifesaving Gold Medal and a Massachusetts Humane Society Bravery Award.

APPENDIX A

Efficiency of various DG technologies [3]

Most fuel cell technologies expect to have efficiencies as high as 50 percent and even as high as 85 percent for combined-cycle hybrid and cogeneration.

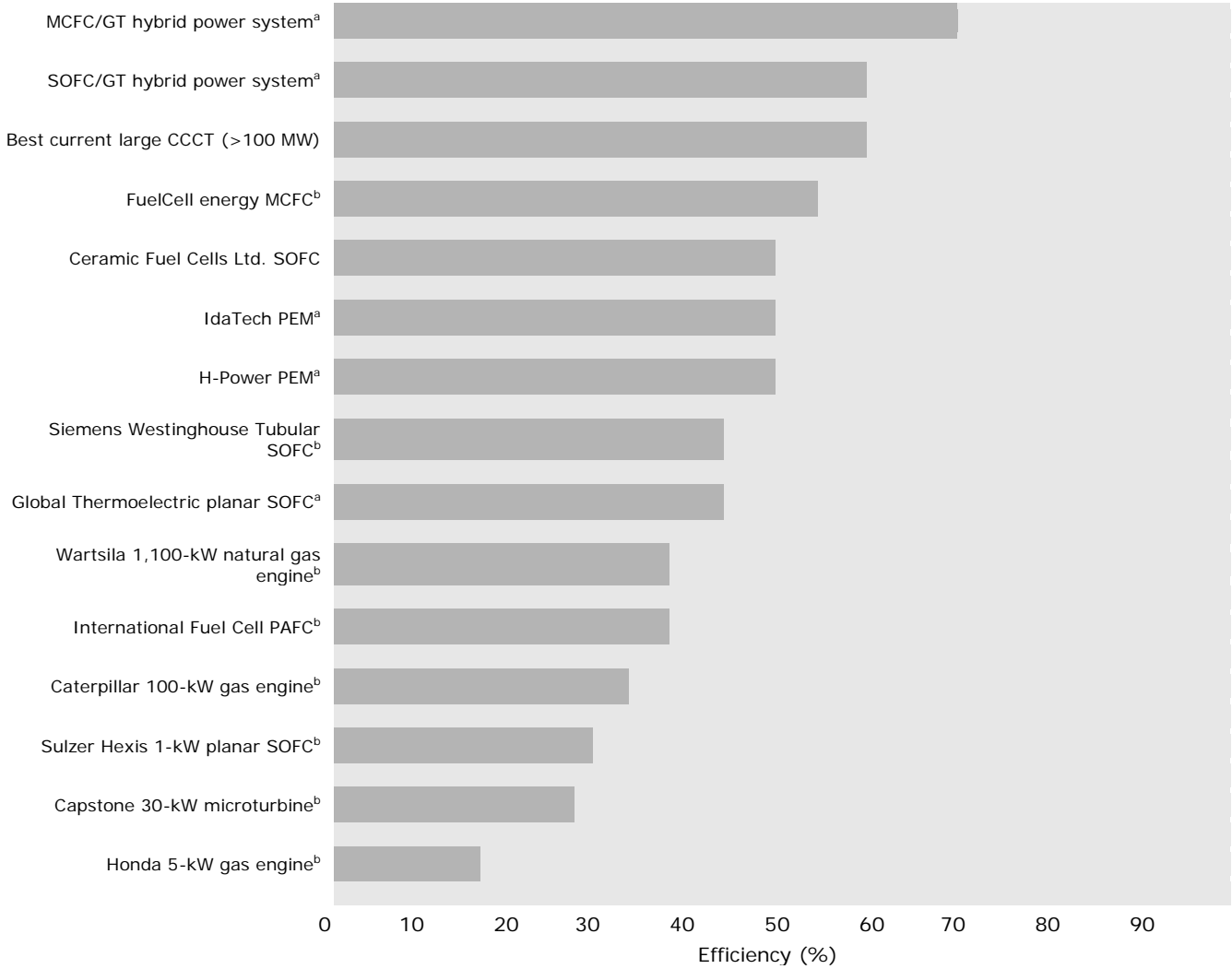

Notes: CCCT = combined-cycle plant, MCFC = molten carbonate fuel cell
 PEM = proton exchange membrane, PAFC = phosphoric acid fuel cell
 SOFC = solid oxide fuel cell
 a. Estimated efficiency based on manufacturer prediction
 b. Actual efficiency based on tested results and verified with the manufacturer

Source: Manufacturer information

APPENDIX B

DOE's Annual Energy Outlook perception on DG and Efficiency [3]

This table displays cost and efficiency comparisons of various types of distributed generation (DG) technologies from the Department of Energy's (DOE) *Annual Energy Outlook 2002*. Although the DOE agrees with the fuel cell industry that efficiencies for fuel cells are better than for other DG technologies, the government's cost outlook predicts fuel cells being more expensive than the other technologies for some time to come.

Year	Fuel cells	Natural gas turbine	Natural Gas engine	Natural gas microturbine
2000				
Cost (\$)	3,674	1,600	1,390	1,970
Efficiency (%)	36	22	28	26
2002				
Cost (\$)	3,282	1,555	1,320	1,785
Efficiency (%)	38	23	29	27
2006				
Cost (\$)	2,834	1,503	1,240	1,574
Efficiency (%)	40	24	29	29
2010				
Cost (\$)	2,329	1,444	1,150	1,337
Efficiency (%)	43	25	30	31
2015				
Cost (\$)	1,713	1,373	1,040	1,047
Efficiency (%)	47	27	30	34
2020				
Cost (\$)	1,433	1,340	990	915
Efficiency (%)	50	28	31	36

Source: U.S. Department of Energy